

15" Intel® Atom™ Processor-Based Operator Panel PC

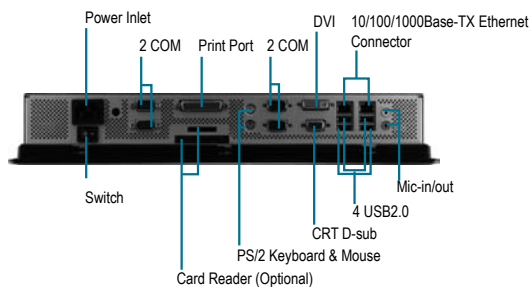

IP-65 Certified Panel with Touch Screen

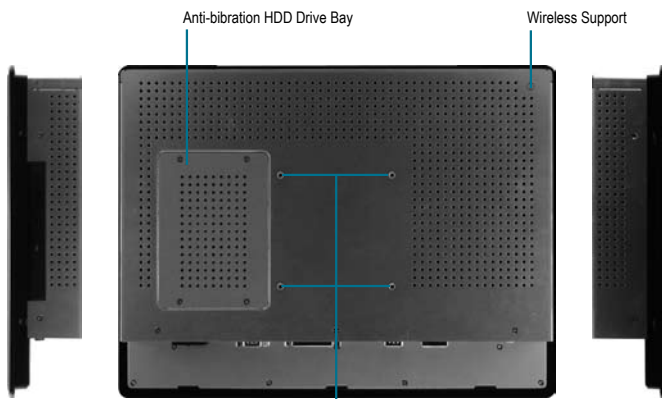

Features

- 15" XGA TFT-LCD
- Onboard Intel® Atom™ Low Power Consumption Processor
- Anti-Vibration Disk Drive Bay
- Touch Screen Support
- Windows® XP Pro For Embedded, Windows® XP Embedded, Windows® 7 Support
- Slim Type Panel PC With Fanless Solution



Specifications

System	
Processor	Intel® Atom™ N270 processor 1.6 GHz
System Memory	DDRII DIMM x 1, Max 2 G (DDRII 400/533 MHz)
LCD/CRT Controller	Intel® 945GSE integrated
Ethernet	10/100/1000Base-TX, RJ-45 x 2
I/O Port	RS-232 x 3, RS-232/422/485 x 1 USB 2.0 x 4 Parallel x 1 VGA x 1 DVI x 1 PS/2 keyboard x 1, PS/2 mouse x 1 MIC-in, Line-out
Storage Disk Drive	Slim CD-ROM / Combo / DVD Anti-vibration 2.5" Hard Disk Drive bay (SATA or IDE)
Expansion Slot	Mini-PCI slot x 1
OS Support	Windows® XP Pro for Embedded, Windows® XP Embedded, Windows® 7
Mechanical	
Construction	IP-65 Plastic Panel with metal back cover
Color	Black
Mounting	Panel Mount/VESA 100mm
Dimension	16" (W) x 12.2" (H) x 2.6" (D) (407mm x 310.5mm x 67.2mm)
Carton Dimension	20.67" (W) x 18.31" (H) x 9.1" (D) (525mm x 465mm x 230mm)
Gross Weight	14.3 lb (6.5 Kg)
Net Weight	12.1 lb (5.5 Kg)
Environmental	
Operating Temperature	32°F ~ 104°F (0°C ~ 40°C)
Storage Temperature	-4°F ~ 122°F (-20°C ~ 50°C)
Operating Humidity	10% to 90% @ 35°C, non-condensing
Vibration	Random operation 1 G, 5~500Hz
Shock	15G peak acceleration (11 msec. Duration)
EMC	CE/ FCC Class A
Power Supply	
AC-DC input	AC 100 ~230V
DC-DC Input	DC 9 ~30V
LCD	
Display Type	15"
Max. Resolution	1024 x 768
Max. Color	16.7 Million
Dot Size	0.297 x 0.297
Luminance (Typical)	250 nits
View Angle	150°(H)/140°(V)
Back Light MTBF (Hours)	50,000
TouchScreen	
Type	5-wire, Analog Resistive
Resolution	2048 x 2048
Light Transmission	80%
Lifetime	35 million activations

AOP-9150

Dimension

Unit: mm

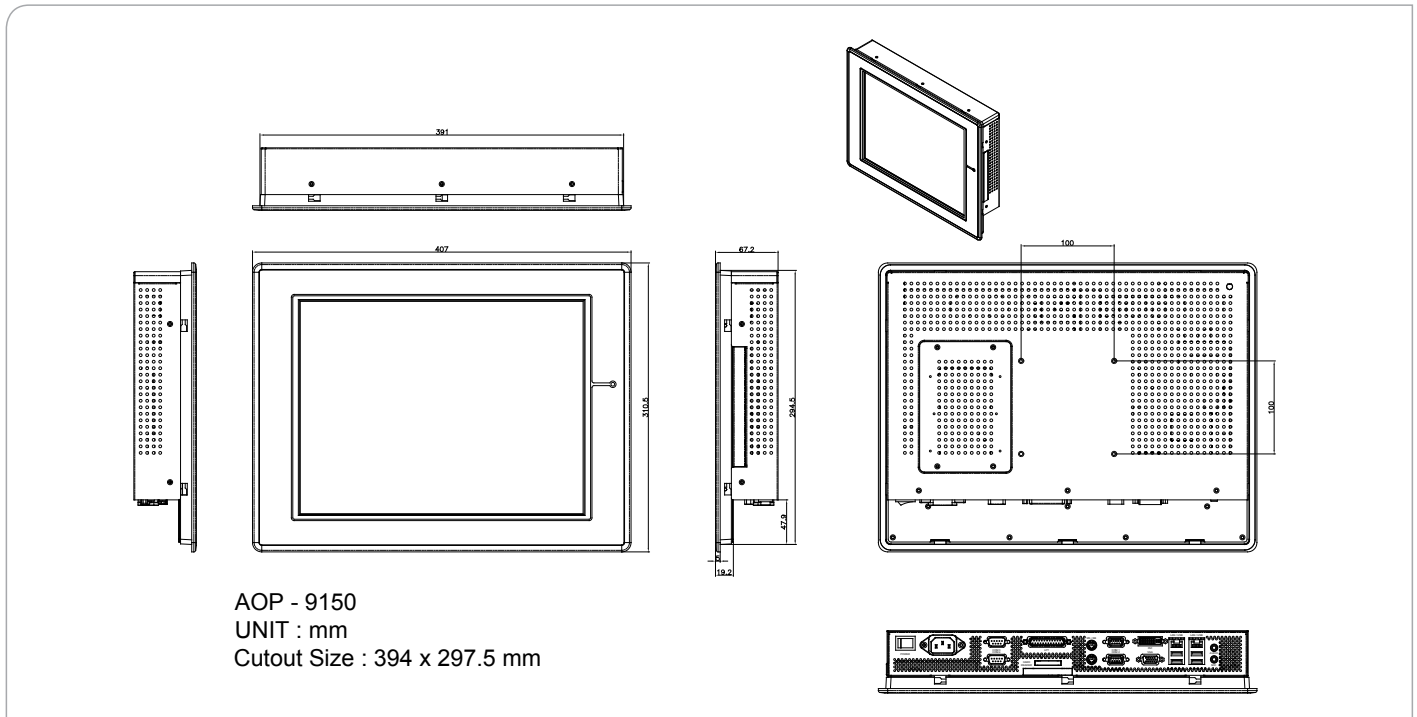

Ordering Information

- **TF-AOP-9150HT-A1-1010**
Fanless Operator Panel, Intel® N270 1.6 GHz, 15" TFT, AC, R-TS
- **TF-AOP-9150HT-A2-1010**
Fanless Operator Panel, Intel® N270 1.6 GHz, 15" TFT, DC, R-TS

Optional Accessories

- **9741666646**
Wireless LAN Kit, IEEE802.11b/g, with Antenna
- **ARM-WK075-0**
Wallmount Kit with VESA 75/100mm Standards
- **ARM-LA0115**
Swivel Arm with VESA 75/100mm Standards
- **1702031802**
Power Cord (US Type)
- **1702031803**
Power Cord (European Type)
- **170203180E**
Power Cord (Japanese Type)
- **9697C20012-DIP**
Card Reader
- **STAND-9150B0**
Desktop Stand
- Slim CD-ROM/Combo/DVD-ROM
- 2.5" Hard Disk Drive